

УДК 621.314.1

Dmitri Vinnikov<sup>1</sup>, Janis Zakis<sup>1,2</sup>, Liisa Liivik<sup>1</sup>, Ivars Rankis<sup>2</sup><sup>1</sup>Power Electronics Group, Department of Electrical Engineering  
Tallinn University of Technology, Ehitajate tee 5, 19086 Tallinn, Estonia,  
e-mail: dmitri.vinnikov@ieee.org<sup>2</sup>Institute of Industrial Electronics and Electrical Engineering, Riga Technical University,  
Kronvalda blv. 1, LV-1010 Riga, Latvia, e-mail: janis.zakis@ieee.org**qZS-BASED SOFT-SWITCHING DC/DC CONVERTER  
WITH A SERIES RESONANT LC CIRCUIT**

*This paper discusses further modifications of the recent popular qZS-based DC/DC converter design by the introduction of the resonant LC circuit in series to the primary winding of the isolation transformer. The primary aim is to achieve the zero voltage and zero current switching of transistors. As an additional benefit of the resonant LC circuit, the converter is able to perform the voltage buck function simply by changing the switching frequency of the transistors. The control principle of the converter and its main operating modes are explained. The theoretical assumptions are experimentally verified by help of the small-scale testbench of the converter.*

**Keywords:** qZS-based DC/DC converter, series resonant DC/DC converter, soft switching.

*Запропонована модифікація схеми квазі-імпедансного DC/DC перетворювача шляхом послідовного включення резонансної LC-ланки та первинної обмотки ізолюючого трансформатора. Це дозволяє досягти комутації транзисторів при нульовому струмі та нульовій напрузі. До додаткових переваг запропонованої схеми DC/DC перетворювача можна віднести здатність понижувати напругу шляхом зміни частоти комутації транзисторів. Розглянутий принцип керування перетворювачем та його основні режими роботи. Запропоновані гіпотези були експериментально підтверджені за допомогою експериментального макету.*

**Ключевые слова:** квазі-імпедансный DC/DC перетворювач, DC/DC перетворювач з послідовною резонансною ланкою, м'яка комутація

**Introduction**

The quasi-Z-source (qZS) based DC/DC converter is a novel approach to the galvanically isolated step-up DC/DC converters [1, 2]. Thanks to the qZS-network at the input side, the converter features such important benefits as continuous input current, shoot-through immunity, low inrush current during start-up, and wide regulation freedom of the inverter (integrated buck-boost functionality). Due to its properties, the converter is especially suitable as a power conditioner for renewable energy sources.

Further modification of the qZS-based DC/DC converter is analyzed here. The new topology was derived simply by adding the resonant LC circuit in series with the primary winding of the isolation transformer (Fig. 1a). As in a baseline topology, the output voltage is controlled by the variation of the shoot-through duty cycle, which could be realized in different ways [3]. In our case the shoot-through states are created by the overlap of active states, as shown in Fig. 1b. It is remarkable that the inverter operates without dead time and the duty cycle of active states of transistors is greater than or equal to 0.5. If the active state duty cycle is greater than 0.5, overlapping occurs and the shoot-through states will be created. During this operating mode the current through the inverter switches reaches its maximum, the voltage across the inverter bridge ( $U_{DC}$ ) and, consequently, the voltage of the primary winding of the isolation transformer ( $U_{Tr}$ ) drops to zero. The operating period of the isolation transformer in this control method consists of a shoot-through state  $t_S$  and an active state  $t_A$ :

$$\frac{t_A}{T} + \frac{t_S}{T} = D_A + D_S = 1, \quad (1)$$

$$T = t_A + t_S. \quad (2)$$

where  $D_A$  and  $D_S$  are the duty cycles of an active and a shoot-through state, correspondingly. As Eq. (1) and Fig. 1b show, the duty cycle of the active state will vary with the variation of the shoot-through duty cycle. It approaches its maximum in the non-shoot-through mode, when the input voltage is high enough and

the shoot-through states are eliminated, and vice versa, in the conditions of minimal input voltage where the shoot-through duty cycle is maximal, the duty cycle of active states will have a minimum value. It should also be noted that for the proposed voltage-fed qZS topology with the positive input voltage, the maximum shoot-through duty cycle should never exceed 0.5 or the system could get instable.

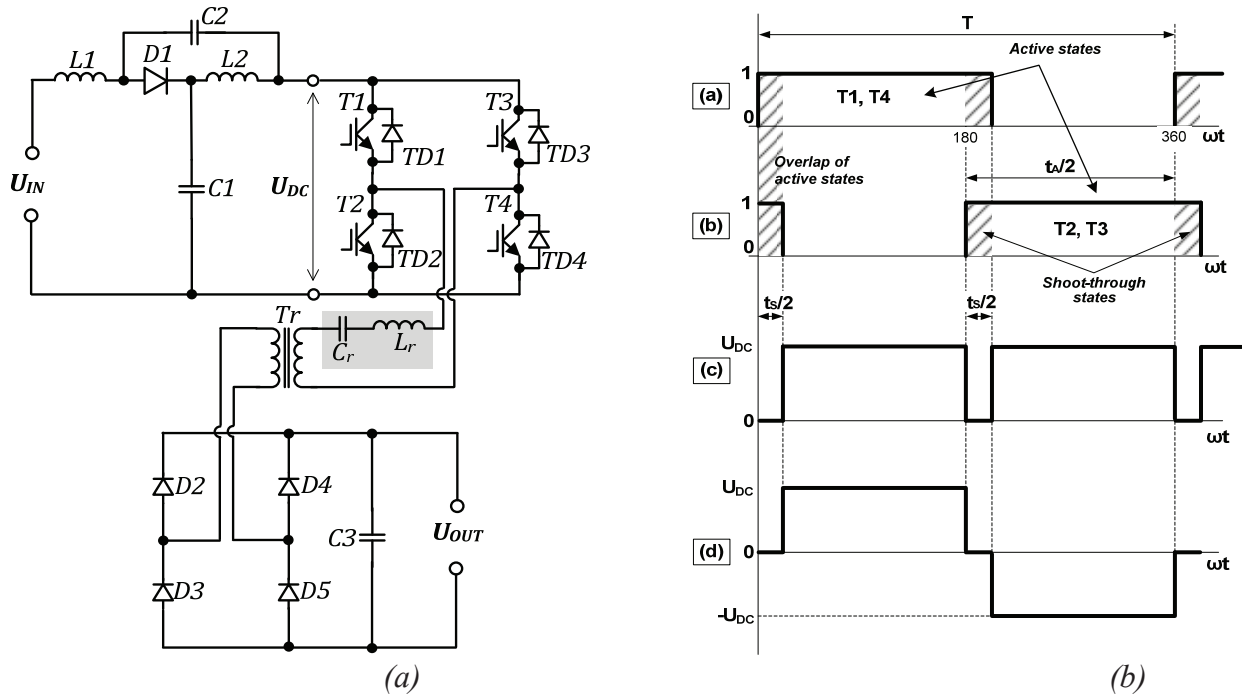

Fig. 1

Based on this methodology, the switching states sequence is presented in Table 1. The states are shown for one switching period of the isolation transformer. As it can be seen, the transistors work with the same switching frequencies, thus have equal switching losses.

Table 1

States	T1	T2	T3	T4
Active state	1	0	0	1
Shoot-through state	1	1	1	1
Active state	0	1	1	0
Shoot-through state	1	1	1	1

**Operation Modes of the Proposed Converter.** The proposed qZS-based resonant DC/DC converter could operate in three basic modes: normal (or non-shoot-through), boost (or shoot-through) and buck (or series resonant) mode. The first two modes are similar to those of the traditional qZS-based DC/DC converter, however the buck mode provides an additional advantage gained by the implementation of the resonant network.

In the normal mode the input voltage is equal to the DC-link voltage ( $U_{IN}=U_{DC}$ ). The switching frequency of the inverter switches is equal to the resonant frequency ( $f_{SW}=f_r$ ) and can be defined as

$$f_{SW} = f_r = \frac{1}{2\pi} \sqrt{\frac{1}{L_r C_r}}, \tag{3}$$

where  $L_r$  and  $C_r$  are the inductance and capacitance values of the resonant inductor and the capacitor, respectively. Fig. 2 shows the theoretical operating waveforms of the qZS-based resonant DC/DC converter topology in the normal mode. Switches here can be turned on and off at perfect zero voltage and zero current condition. Therefore, in this mode, maximum efficiency can be achieved. In this operation mode the current in the resonant circuit can be assumed as a sine wave but the total voltage across both of the reactive elements is zero. It is assumed that diagonal switches ( $T1, T4$  and  $T2, T3$ ) are conducting half the period. At the current  $i_r > 0$ , the voltage applied to the resonant circuit is

$$U_r = U_{IN} - U_{OUT} \cdot k_{Tr}, \tag{4}$$

where  $U_{OUT}$  is the output voltage of the converter and  $k_{Tr}=N_1/N_2$  is the transformer turns ratio.

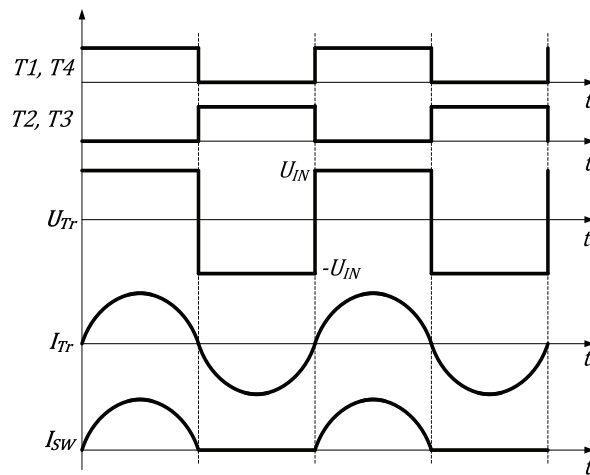

Fig. 2

The same voltage is also applied to the resistance  $R_r$  that is actually the impedance of the resonant circuit. Output voltage  $U_{OUT}$  of the converter can be expressed as

$$U_{OUT} = \frac{2I_{Tr,m} \cdot k_{Tr} \cdot R_l}{\pi}, \quad (5)$$

where  $R_l$  is the resistance of a load. Average current per half cycle of the resonant circuit is

$$I_{Tr} = \frac{2 \cdot I_{Tr,m}}{\pi}. \quad (6)$$

Taking into account that the input power of the converter is  $P_{IN} = U_{IN} \cdot I_{IN}$ , the power balance between the resonant circuit and load can be expressed as

$$\frac{2I_{Tr,m}}{\pi} \cdot U_{IN} - \frac{I_{Tr,m}^2}{2} \cdot R_r = \frac{4I_{Tr,m}^2 \cdot k_{Tr}^2 \cdot R_l}{\pi^2}. \quad (7)$$

The amplitude value of the resonant circuit current can be found as

$$I_{Tr,m} = \frac{4 \cdot \pi \cdot U_{IN}}{\pi^2 R_r + 8k_{Tr}^2 R_l}. \quad (8)$$

If the input voltage of the converter drops below the nominal value, the converter starts operation in the boost mode. In order to boost the input voltage during this mode, a special switching state — the shoot-through state — is implemented in the inverter control. During the shoot-through states, the primary winding of the isolation transformer is shorted through all switches of both phase legs. This shoot-through state (or vector) is forbidden in the traditional voltage source inverters because it would cause a short circuit of DC capacitors and destruction of power switches. The qZS-network makes the shoot-through states possible, effectively protecting the circuit from damage. Moreover, the shoot-through states are used to boost the magnetic energy stored in the DC-side inductors  $L1$  and  $L2$  without short circuiting the DC capacitors  $C1$  and  $C2$ . This increase in the magnetic energy, in turn, provides the boost of the voltage seen on the inverter output during the active states. In this operation mode the switching frequency of inverter switches  $f_{SW}$  is fixed to the resonant frequency  $f_r$ . Fig. 3 shows general operation waveforms in the boost mode where switches can be turned on and off at almost perfect zero voltage and zero current condition.

In the boost operating mode the shape of the resonant circuit current ( $I_{Tr}$ ) can be also assumed as a sine wave and the relation between the amplitude value of this current and the output voltage can be described using (5). Power losses in the resonant circuit can be calculated as  $0.5 \cdot I_{Tr,m}^2 \cdot R_r$ . However, some additional power losses caused by the shoot-through states of the qZS-inverter will appear in the boost mode. These losses can be simply described as  $I_{IN}^2 \cdot R_{qZS}$ , where  $I_{IN}$  is the input current of the converter and  $R_{qZS}$  is the equivalent resistance of the qZS-network during shoot-through states.

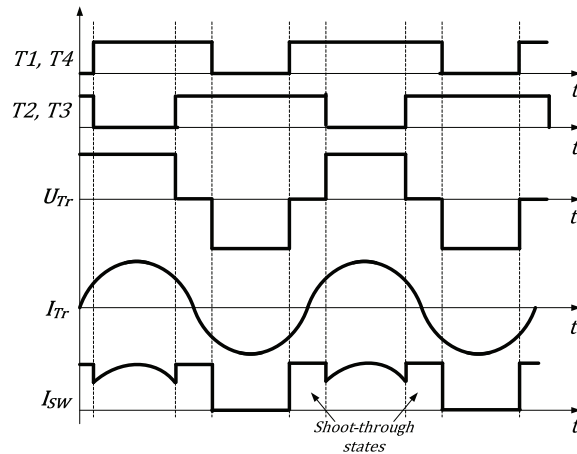

Fig. 3

For the boost mode, the input current of the converter can be expressed as

$$I_{IN} = \frac{2 \cdot I_{Tr,m}}{\pi(1-2D_S)} \quad (9)$$

Neglecting losses in the transformer and the rectifier, the power balance of the converter can be written as

$$P_{IN} = \Delta P_{qZS} + \Delta P_{Rr} + P_{OUT} \quad (10)$$

Inserting the corresponding expressions in the power balance equation (10), the amplitude current of the resonant circuit during the boost mode can be expressed as

$$I_{TR,m} = \frac{4 \cdot U_{IN} \pi (1 - 2D_S)}{8R_{qZS} + 8k_{Tr}^2 R_l (1 - 2D_S)^2 + \pi^2 R_r (1 - 2D_S)^2} \quad (11)$$

In the proposed topology the buck mode is an extra benefit over a baseline solution. In the buck mode the qZS-based resonant DC/DC converter operates as a conventional series resonant converter [4-8] and controls the output voltage by increasing the switching frequency of the qZS-inverter from the resonant frequency  $f_r$  to its maximum switching frequency ( $f_{sw,max}$ ). The theoretical operational waveforms in this mode are depicted in Fig. 4. In this configuration, the resonant tank and the load act as a voltage divider. By changing the switching frequency, the impedance of the resonant circuit will also change. Since it is a voltage divider, the DC gain of the qZS-based resonant DC/DC in this operating mode will be always lower than 1.

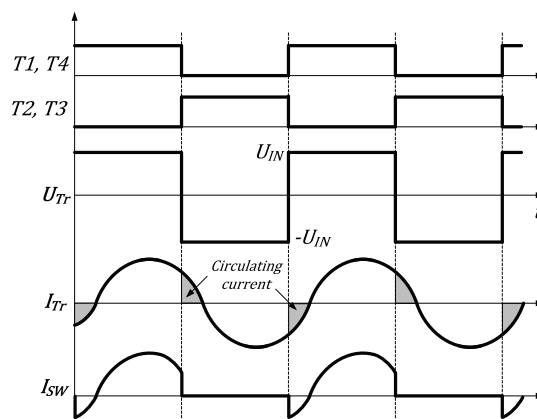

Fig. 4

**Experimental Verification.** To verify the theoretical assumptions an experimental prototype (Fig. 5) was assembled in accordance with the schematics shown in Fig. 1a. Its main component types and values are specified in Table 2. The switching frequency of the qZS-inverter was set to 23 kHz. The series resonant tank was also designed for 23 kHz resonance frequency and consists of a 48  $\mu$ H inductor and 1  $\mu$ F capacitor. During the experiments the converter was studied in three operating points according to Table 3.



Fig. 5

Table 2

Component	Type	Value
C1, C2	Chip Monolithic Ceramic Capacitor SMD1210 X7R 2.2uF 100V GRM32ER72A225K	13μF (matrix configuration)
C3	Metallized Polypropylene Film Capacitors EPCOSB32776G4406	40 uF
L1, L2	Low Profile, High Current SMD Inductors IHLP-6767GZ-A1	56μH (matrix configuration)
Tr	Payton Planar	n=1/1
D1	SiC diode CREE C3D20060D	20A/600 V
T1-T4	N-Channel Si MOSFET FCH47N60N	47A/600 V
Driver core	ACPL-H342-000E	2.5A/15-30V

Table 3

Operating point	$U_{IN}$ (V)	$D_S$	$D_A$	$f_{sw}$ (kHz)	$U_{OUT}$ (V)	Power (W)
1 (normal mode)	100	0	1	23	95	500
2 (boost mode)	50	0.25	0.75	23	95	500
3 (buck mode)	150	0	1	45	95	500

First experiments (Figs. 6-8) were made at the nominal input voltage when the qZS-inverter operates as a traditional voltage source inverter. The switching frequency was  $f_{sw}=f_r=23$  kHz. Inverter switches operated at their maximum possible active state duty cycle ( $D_A=1$ ) without any deadtime.

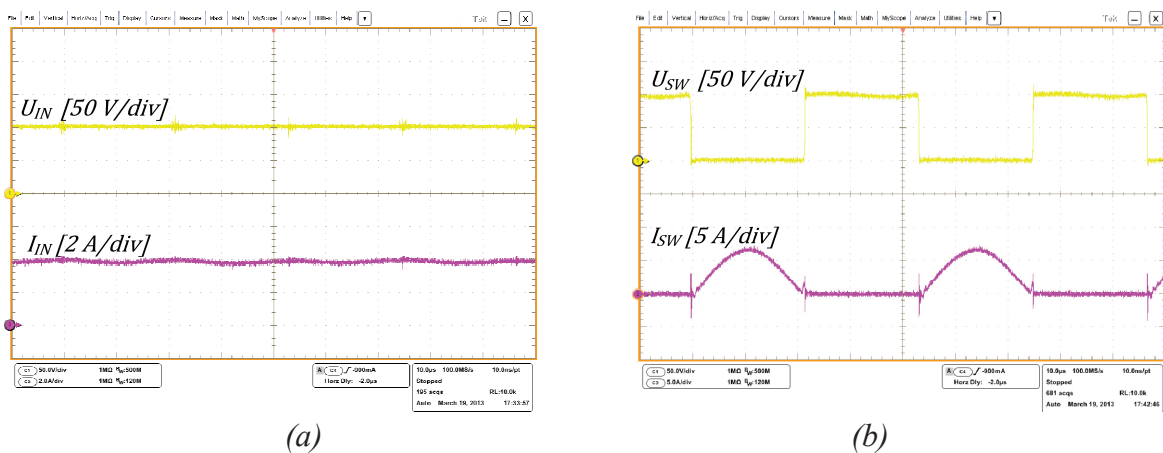

Fig. 6

Fig. 6a shows that the input voltage and current have linear shapes without any intolerable ripple. The intermediate DC-link voltage  $U_{DC}$  equals the input voltage  $U_{IN}$ . Fig. 6b shows that transistor switches

turned on and off at zero voltage and zero current. As shown in Fig. 7b, the current shape of the transformer current is close to a sine wave. Moreover, there is no circulating component in the transformer current. Thus, it could be expected that the maximal efficiency of the converter can be achieved in this operation mode.

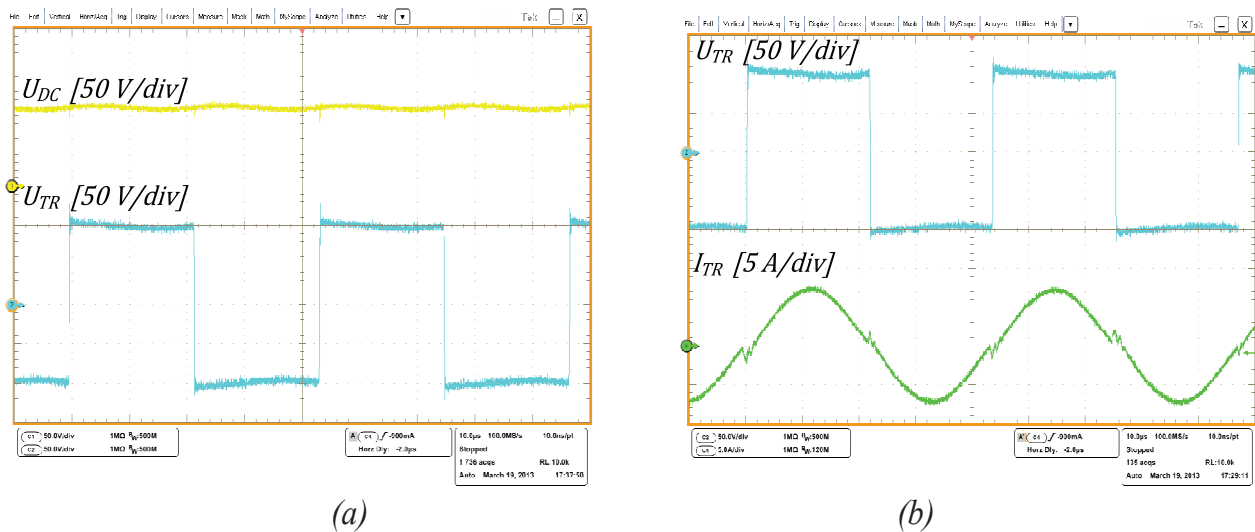

Fig. 7

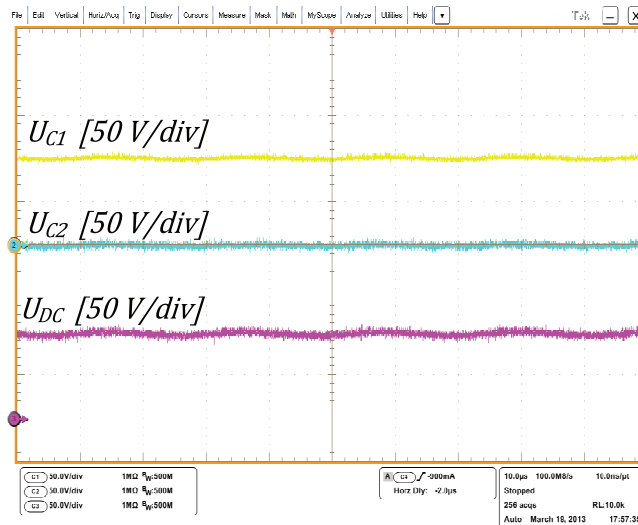
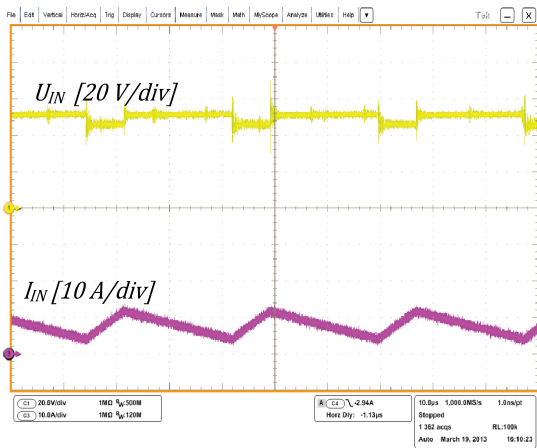
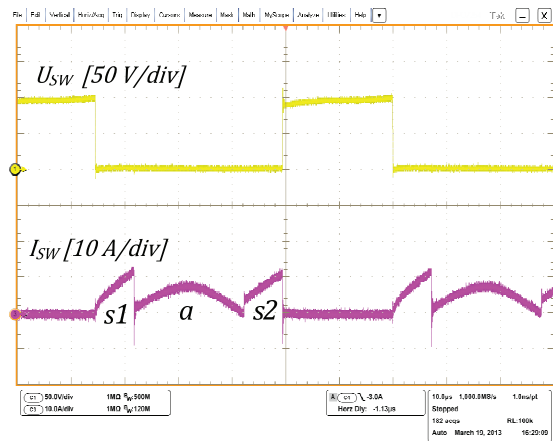

Fig. 8

In the second operating point the converter was tested at the minimum input voltage ( $U_{IN}=50$  V) when the maximal shoot-through duty cycle ( $D_S$ ) was applied in order to obtain the rated output voltage ( $U_{OUT}=95$  V). Operation frequency of transistor switches  $f_{SW}$  corresponds to the resonant frequency  $f_r$  of the resonant circuit ( $f_{SW}=f_r=23$  kHz). Fig. 9a shows the input voltage and input current when the inverter switches ( $T1...T4$ ) are operated at the maximal shoot-through duty cycle ( $D_S=0.25$ ). The input current shape shows that the converter operates in the continuous conduction mode (CCM). Fig. 9b shows that during the first shoot-through state ( $s1$ ) and active state ( $a$ ) intervals, the transistors are fully soft switched. The second shoot-through state ( $s2$ ) starts in the zero voltage conditions but its turn-off is hard switched. The current shape of the transformer current is still close to a sine wave (Fig. 10b). Fig. 11 presents both capacitor voltages ( $U_{C1}$  and  $U_{C2}$ ) and the intermediate DC-link voltage of the qZS-inverter. As predicted theoretically,  $U_{DC}$  is a sum of capacitor voltages of the qZS network.



(a)



(b)

Fig. 9

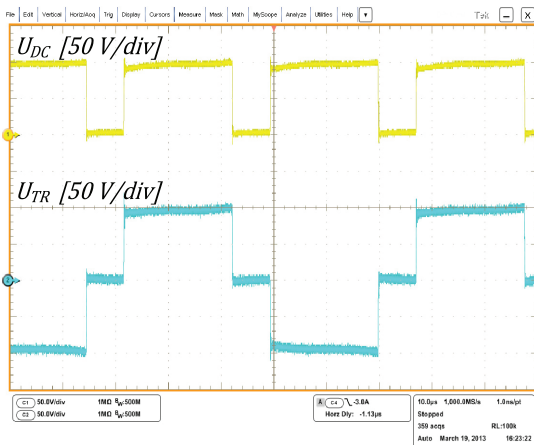

(a)

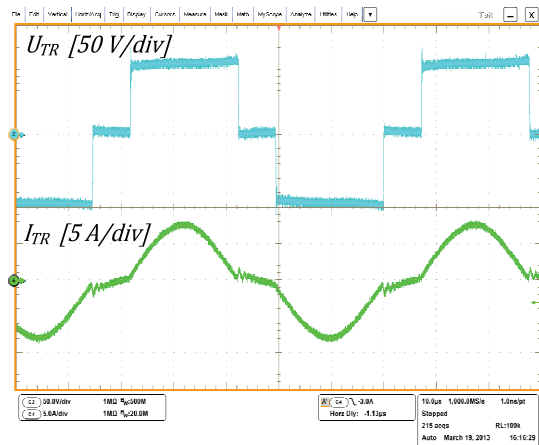

(b)

Fig. 10

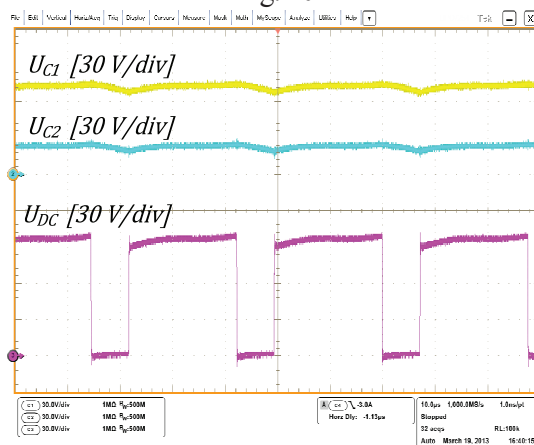

Fig. 11

To verify the converter in the buck mode the input voltage  $U_{IN}$  was set to its maximum value (150 V) and  $U_{OUT}$  was regulated to 95 V level. The procedure was similar to that of the traditional series resonant DC/DC converter - by increasing the switching frequency of transistors up to 45 kHz. The circulating current in this mode does not contribute to the power transfer of the converter (Figs. 12b and 13b). The input voltage and current waveforms (Fig. 12a) are similar to those of the normal operating mode (Fig. 6a). Another distinction of the buck operation mode is that the transformer voltage and current are phase-shifted.

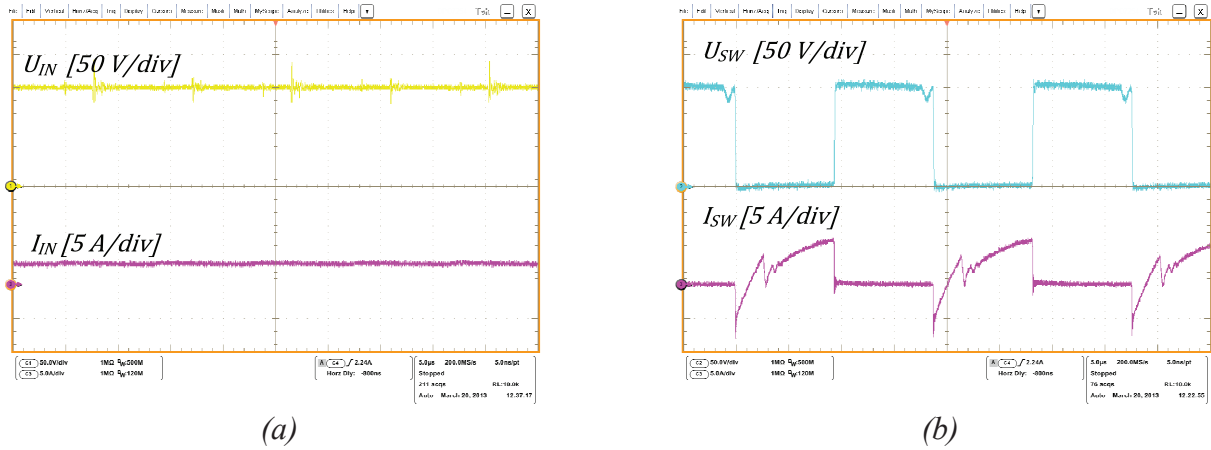

Fig. 12

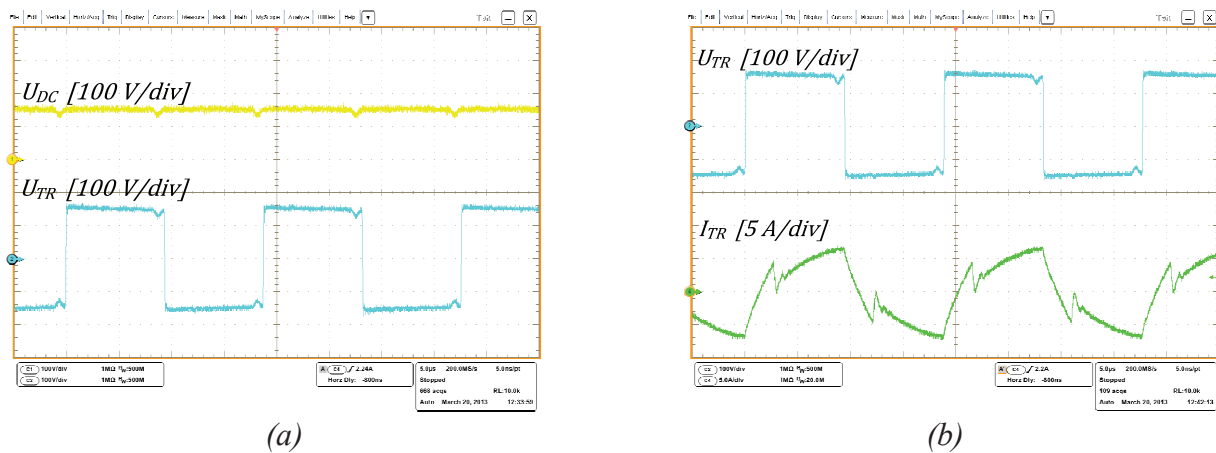

Fig. 13

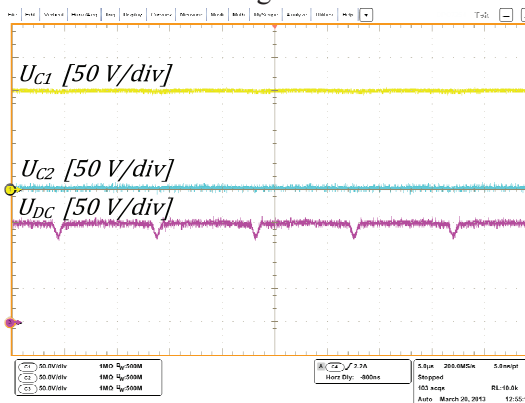

Fig. 14

### Conclusions

The proposed qZS-based resonant DC/DC converter is a modified version of the traditional qZS-based DC/DC converter. It can operate in the buck and boost operation mode in contrast to a traditional series resonant converter that performs only the voltage buck function. Thus it is a very desirable circuit topology when the input voltage and the load range of the converter are very wide. Experimental results showed that thanks to the implemented series resonant LC circuit, the qZS-based DC/DC converter could be soft-switched in all operating points except minor power dissipation at the turn-off transient of the second shoot-through state in the shoot-through mode. Moreover, the new topology combines the advantages of the series resonant DC/DC converter with those of the qZS-based DC/DC converter:



- voltage buck mode could be realized by increasing the switching frequency from the resonance frequency point;
- series capacitor  $C_r$  blocks the DC voltage, thus avoiding the transformer saturation,
- continuous input current,
- shoot-through immunity,
- low inrush current during start-up.

**Acknowledgments.** This research work was financed by Estonian Ministry of Education and Research (project SF0140016s11), Estonian Research Council (Grant G8538) and Latvian Council of Science (Grant 416/2012).

1. Vinnikov, D.; Roasto, I., "Quasi-Z-Source-Based Isolated DC/DC Converters for Distributed Power Generation," *IEEE Transactions on Industrial Electronics*, vol. 58, no. 1, pp. 192-201, Jan. 2011.

2. Vinnikov, D.; Roasto, I.; Strzelecki, R.; Adamowicz, M., "Step-Up DC/DC Converters with Cascaded Quasi-Z-Source Network," *IEEE Transactions on Industrial Electronics*, vol. 59, no. 10, pp. 3727-3736, Oct. 2012.

3. Roasto, I.; Vinnikov, D.; Zakis, J.; Husev, O., "New Shoot-Through Control Methods for qZSI-Based DC/DC Converters," *IEEE Transactions on Industrial Informatics*, vol. 9, no. 2, pp. 640-647, May 2013.

4. Honnyong Cha; Peng, F.Z.; Dong Wook Yoo, "Z-source resonant DC-DC converter for wide input voltage and load variation," *International Power Electronics Conference (IPEC'2010)*, pp. 995-1000, 21-24 June 2010.

5. Rangan, V.; Helmicki, A.J.; Nebragic, D. D.; Melvin, D. B.; Glos, D., "Non-linear robust control of a series resonant DC/DC converter for bio-medical applications", *Proceedings of the 1996 IEEE International Conference on Control Applications*, pp. 870,875, 15-18 Sep 1996.

6. Vorperian, V.; Čuk, S., "A Complete DC Analysis of the Series Resonant Converter," *IEEE Power Electronics Specialists Conference*, pp. 85-100, June 1982.

7. Witulski, A.; Erickson, R.; "Steady-State Analysis of the Series Resonant Converter," *IEEE Transactions on Aerospace and Electronic Systems*, vol. 19, no. 6, pp.791-799, Nov.1985.

8. Witulski, A.; Erickson, R.; "Design of Series Resonant Converter for Minimum Component Stress," *IEEE Transactions on Aerospace and Electronic Systems*, vol. 22, no. 4, pp.356-363, July 1986.

## КВАЗИ-ИМПЕДАНСНЫЙ DC/DC ПРЕОБРАЗОВАТЕЛЬ С ПОСЛЕДОВАТЕЛЬНЫМ РЕЗОНАНСНЫМ LC-ЗВЕНОМ И МЯГКОЙ КОММУТАЦИЕЙ

Дмитрий Винников<sup>1</sup>, Янис Закис<sup>1,2</sup>, Лиза Лиивик<sup>1</sup>, Иварс Ранкис<sup>1,2</sup>

<sup>1</sup> Группа Силовой Электроники, Таллинский Технический Университет,  
Институт Электротехники

ул. Эхитаяте 5, Таллин, 19086, Эстония, e-mail: dmitri.vinnikov@ieee.org

<sup>2</sup> Институт Промышленной Электроники и Электротехники, Рижский Технический  
Университет

Бульвард Кронвальда 1, LV-1010 Рига, Латвия, e-mail: janis.zakis@ieee.org

Предложена модификация схемы квази-импедансного DC/DC преобразователя путем последовательного включения резонансного LC-звена и первичной обмотки изолирующего трансформатора. Это позволяет достичь коммутации транзисторов при нулевом токе и нулевом напряжении. К дополнительным преимуществам предложенной схемы DC/DC преобразователя можно отнести способность понижать напряжение путем изменения частоты коммутации транзисторов. Рассмотрен принцип управления преобразователем и его основные режимы работы. Предложенные гипотезы были экспериментально подтверждены с помощью лабораторного макета.

**Ключевые слова:** квази-импедансный DC/DC преобразователь, DC/DC преобразователь с последовательным резонансным контуром, мягкая коммутация