

UDC 681.3.09

Chupakhin A.

National Technical University of Ukraine “KPI”, Kyiv, Ukraine, e-mail: chupe@ukr.net

SHIELD CURRENT INDUCED NOISE IN AUDIO CABLES

Take an experimental research the "shield-current-induced noise" measurement results for various types of audio cables and developed the circuit model to simulate a behavior of the various length cables in the 10 kHz – 4 MHz range.

Keywords: *electromagnetic compatibility, radio frequency interference, shield-current-induced noise.*

Introduction

Professional audio systems (such as used in cinemas, concert halls, theaters or open-air concerts) are often exposed to interferences. The problem of provisions electromagnetic compatibility in audio equipment describe in papers [1-5].

Neil Muncy [1] has shown that audio frequency current flowing on the shield of twisted-pair audio wiring will be converted to differential mode voltage by any imbalance in the transfer impedance of the cable. Muncy has set up an experiment to study a current flow thorough the shield of an audio cable. With a power amplifier and an output transformer driving the shield with 100 mA sine and square waves at 60 Hz, 600 Hz, and 6 kHz, he measured the voltage induced on the signal pair. He called this voltage “shield-current-induced noise” (SCIN). Its amplitude was proportional to the signal frequency due to the imbalance in magnetic coupling between the shield and the two signal conductors.

Statement of problem and purpose

The purpose of this research is to study SCIN characteristics of audio cables of different types and lengths in the 6KHz-4MHz frequency range. Measurements were performed for the four different lengths of cable – 15 m, 7.5 m, and 3 m.

Measured data. Test setup used to measure shield-current-induced noise (SCIN) (fig. 1.). The test cables are all nearly the same physical size and have the same size conductors, but their SCIN performance

differs within the 30 dB. The differences are due to the drain wire or the lack of it, and its resistance relative to the braid or the foil.

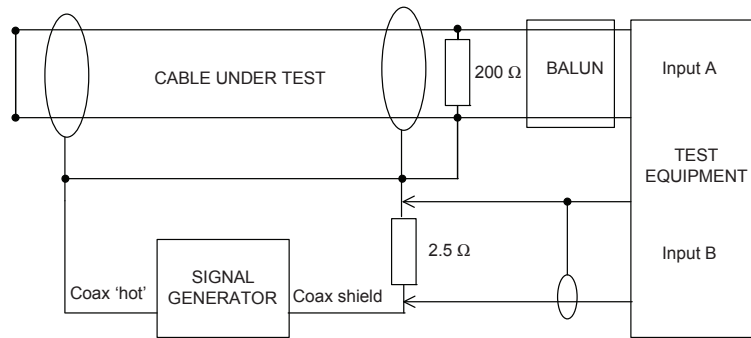

Fig. 1

Circuit model. The author have developed the circuit model shown in (fig. 2) and used it to simulate behavior of the cable and to test the setup shown above.

Since the impedance of an inductor rises linearly with the signal frequency, a voltage with this characteristics will be produced across LTX (LTX is the mutual inductance of the ideal 3 - winding transformer). This will induce similar voltages in the two signal conductors. If they are equal, of course, there would be no differential and no SCIN.

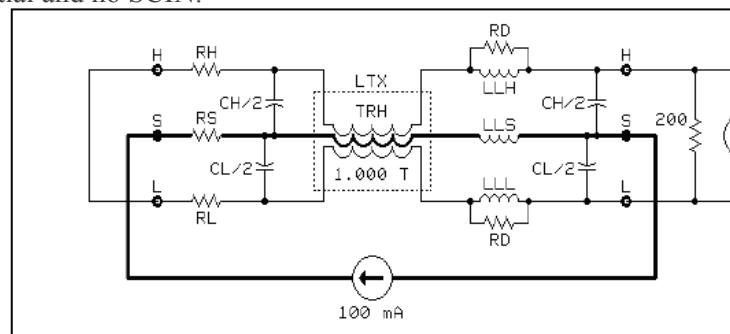

Fig. 2

However, inasmuch as the effective turns ratio of signal high and signal low "windings" of the transformer are mismatched, a fraction of the induced common-mode voltage will appear as differential. At audio frequencies, this is the dominant coupling mechanism. In the cable simulated here, a turns ratio mismatch of 1.2% ($TRH = 1.012$) have produced an excellent correlation with the measured values at low frequencies.

Fig. 3 shows simulated SCIN for the three different lengths (15 m, 7.5 m, and 3 m.). Fig. 4 shows the simulation of 7.5 m. length foil/drain cable of a fairly common 5% capacitance imbalance.

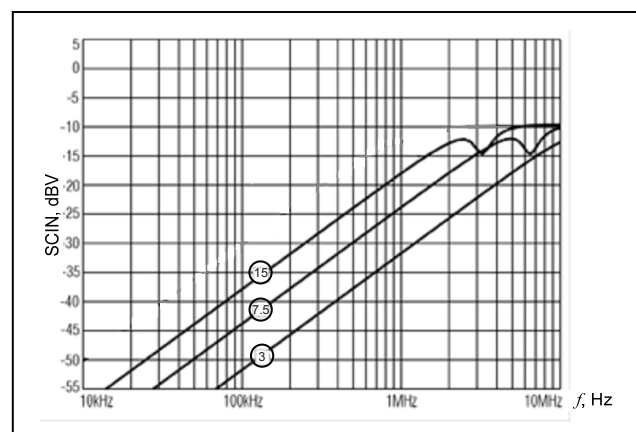

Fig. 3

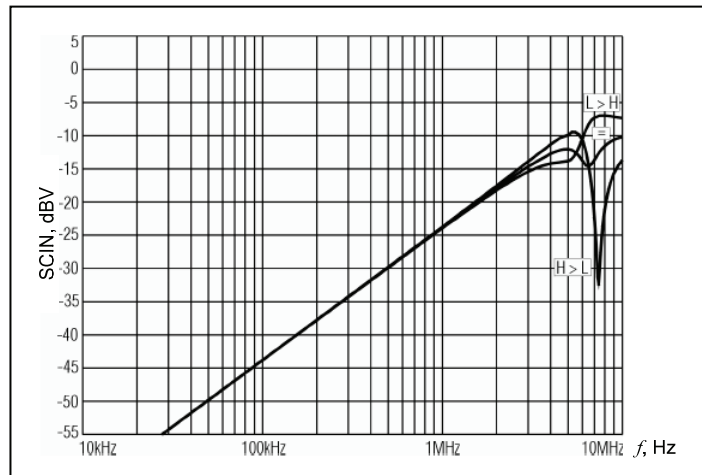

Fig. 4

Conclusions

The results are measurements and simulate of different cable types and lengths in research range 10 kHz - 4 MHz to show that SCIN increases with frequency. The type of shield construction (braid or foil) is also of importance. Until foil/drain cable is replaced by braid-shielded cable for permanent installation, it is critical that audio equipment have good immunity to differential mode signals above the audio spectrum. SCIN will cause radio frequency to be coupled to the signal pair, so audio equipment must include good low pass filtering to reject it.

1. *N. Muncy*, "Noise Susceptibility in Analog and Digital Signal Processing Systems" *J. Audio Eng. Soc.*, vol. 43, No. 6, 435-453 p. (Eng.)
2. *H. Ott*, *Electromagnetic Compatibility Engineering*, New York: Wiley, 2009. (Eng.)
3. *B. Whitlock*, "Balanced Lines in Audio Systems: Fact, Fiction, and Transformers" *J. Audio Eng. Soc.*, vol. 43, No. 6, 454-464 p. (Eng.)
4. *J. Brown*, "Shield Current Induced Noise", *Synergetic Audio Concepts*, vol. 32, No. 1, 1-2 p., January 2004. (Eng.)
5. *K. Armstrong, T. Waldron*, "AES-X13 and interference free pro-audio systems", *IEEE International Symposium EMC 2002*, Minneapolis, Minn., vol. 1, 434 – 439 p., August 2002. (Eng.)